

# EVERY DENNISON MARKETING SPECIFICATION

© 2019 EVERY DENNISON CORPORATION. ALL RIGHTS RESERVED

## HISTORY

REV.	DATE	DESCRIPTION
A	03.02.20	RELEASED

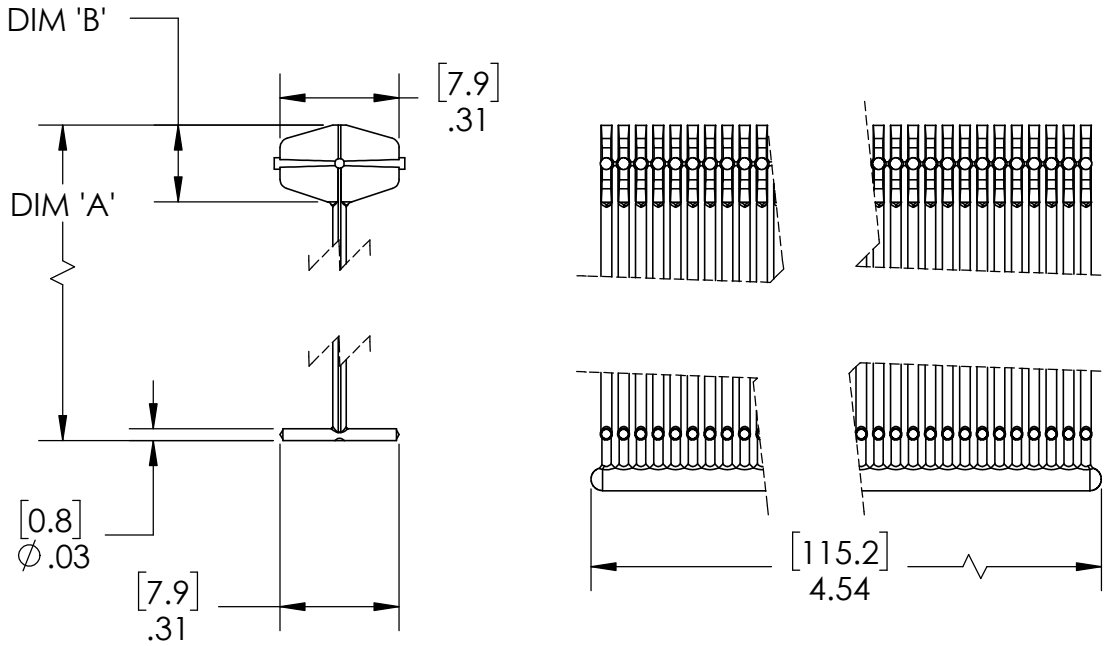

STOCK NUMBER	REV	COLOR	DIM 'A'	DIM 'B'	WEIGHT/CLIP
17050-0	A	LT GRAY	.75 [19]	.25 [6.3]	3.2 GRAMS
17051-0	A	GRAY	.75 [19]	.25 [6.3]	3.2 GRAMS
17052-0	A	LT GRAY	2.25 [57]	.20 [5.1]	4.4 GRAMS
17053-0	A	GRAY	2.25 [57]	.20 [5.1]	4.4 GRAMS

NOMINAL TENSILE STRENGTH	2.5 LB [1135g] MIN
MATERIAL	>70% rPA; </=20% PA; </= 8% COLOR CONC.
WEIGHT	SEE TABLE
CLIP QUANTITY	100
APPLICATION TOOL	MARK III SWIFTACH FF TOOL 10312
PACKAGED IN	10000 PER INNER CARTON 100000 PER MASTER CARTON

APPROVALS:	ENG. APPR.	<i>Dave Schuttler</i>	<i>03.02.20</i>
	Q.A. APPR.	<i>Rick Estano</i>	<i>03.02.20</i>



FASTENER DIVISION  
FITCHBURG, MA 01420 U.S.A.  
TEL. 1-800-225-5913  
FAX. 978-353-8157

SPECIFIED TOLERANCES ARE:		MATERIAL	DESCRIPTION SWIFTACH FF rPA (RECYCLED NYLON)	
.XX ± .03 INCHES	.X ± .7 mm	SEE TABLE	STOCK NO.	REV.
.XXX ± .010 INCHES	.XX ± .25 mm	COLOR		
ANGULAR: ± 2°		SEE TABLE	SEE TABLE	<b>A</b>